

OPTUS

fetch

Quick Start Guide



Make sure you have these items handy

What we've sent you:

A. Fetch box

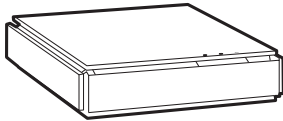

B. Ethernet Cable (3m)

(You'll receive 3 of these if you've ordered a Power Line Adaptor – 1x 3m & 2 x 1.5m)

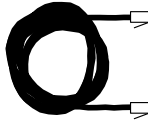

E. HDMI Cable (1.8m)

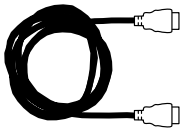

F. Power Supply (1.5m)

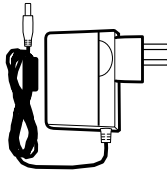

G. 2 x AAA Batteries



H. Remote Control



I. Activation Code

We previously sent this to you via SMS or email. If you are having problems locating your activation code, visit optus.com.au/activationcode

What you should already have:

J. Broadband Modem or Router

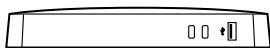

K. TV and TV Remote

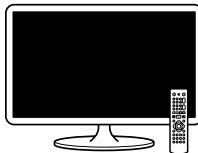

You may have also ordered:

C. Powerline Adaptors

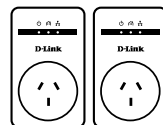

Your set-up checklist

To make sure you don't get lost along the way, here's a checklist of the 3 main connections you'll need to make while setting up:

- 1 Connect to your broadband modem (via Ethernet cable or WiFi)
- 2 Connect to your TV antenna
- 3 Connect to your TV

STEP 1

Connecting to the internet

There are 3 different ways you can connect your Fetch box to the internet – that's via **Ethernet Cable** direct to your modem, using a pair of **Power Line Adaptors** or **WiFi**. The best option for you depends on the location of your broadband modem or router in your home.

Top Tip: Using an Ethernet Cable or a pair of Powerline Adaptors will help you get the most out of your connection.

Option 1

USING ETHERNET CABLE

Recommended if your modem's within 3 metres of your TV.

- 1 Grab the Ethernet Cable (B) and plug one end into the port labelled 'INTERNET' on the back of your Fetch box (A).

- 2 Plug the other end into a spare port on the back of your broadband modem or router (J).

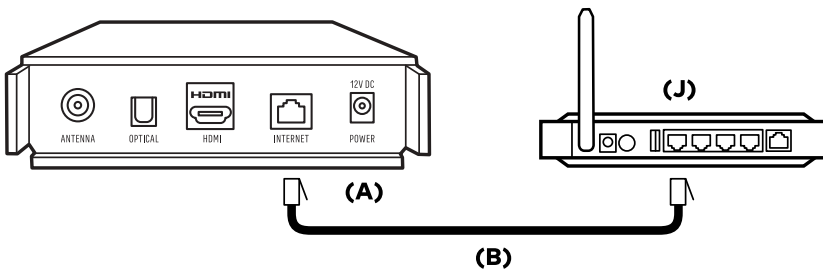

Option 2

POWERLINE ADAPTORS (PLAs)

If your modem's in a different room or more than 3 metres away from your TV.

What are Powerline Adaptors? They're a pair of devices that transmit high-speed data between two power points in different parts of your home using existing electrical wiring - super handy hey!

- 1 If you already have a pair of PLAs continue onto Step 2 (below). If you need a pair of PLAs you can order them at [optus.com.au/myaccount](https://www.optus.com.au/myaccount) or call **133 937** and we can arrange to send one out to you for a small cost.
- 2 Grab one of the PLAs (C) and plug it into the power point nearest to your modem.

- 3 Using the Ethernet Cable (B), plug one end into the port on that PLA and the other end into a free port on the back of your broadband modem or router (J).
- 4 Grab the other PLA (C) and plug it into the power point nearest to your TV (K) and Fetch box (A).
- 5 Finally, plug one end of the second Ethernet Cable (B) into the PLA and the other end into the port labelled 'INTERNET' on the back of your Fetch box (A).

Still need a hand? No problem.

Visit [optus.com.au/fetch/plcinstall](https://www.optus.com.au/fetch/plcinstall) to download our full PLA Setup Guide.

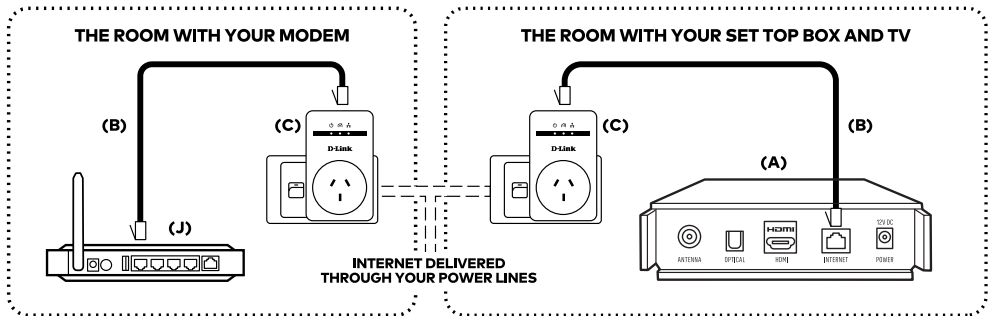

Option 3

WIFI

If your modem's more than 3 metres away from your TV and you have strong WiFi available.

If you're going to connect using WiFi check out Step 6 of this guide after you've completed Steps 2, 3, 4 and 5. For now, continue onto Step 2 below.

STEP 2

Plug in your antenna

- 1 Unplug your existing TV Antenna Cable from the back of your TV (K). Now plug it into the port labelled 'ANTENNA' on the back of your Fetch box (A). The other end stays connected to the Antenna Socket in the wall.

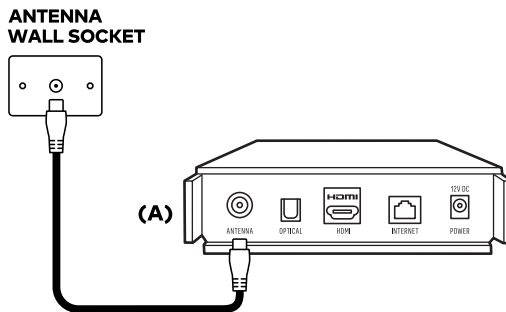

STEP 3

Hook-up your TV

- 1 Plug one end of the HDMI Cable (E) into the port labelled 'HDMI' on the back of your Fetch box (A). Next, plug the other end into a spare HDMI port on your TV (K).

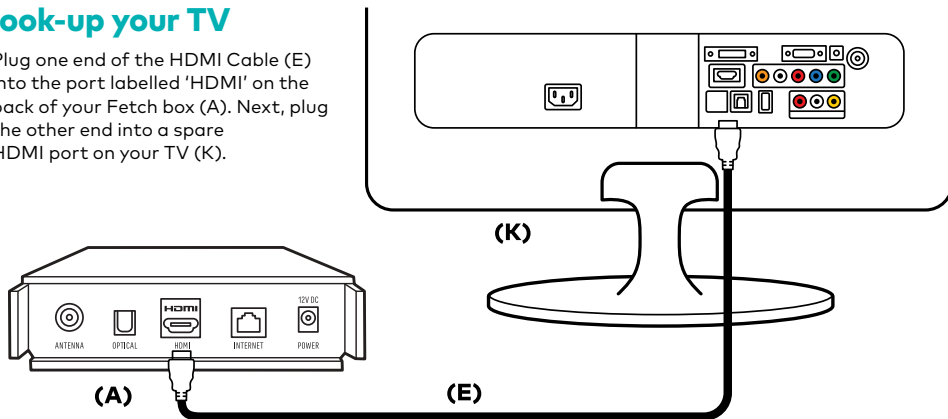

STEP 4

Power up

YOUR FETCH BOX

- 1 Plug the end of the Power Cord (F) into the port labelled 'POWER' on the back of your Fetch box (A).
- 2 Grab the end of the Power Cord (F) and plug it into a power point. Switch the power point ON.

YOUR FETCH REMOTE

- 1 Put the 2 x AAA Batteries (G) into the back of your Fetch remote control (H).

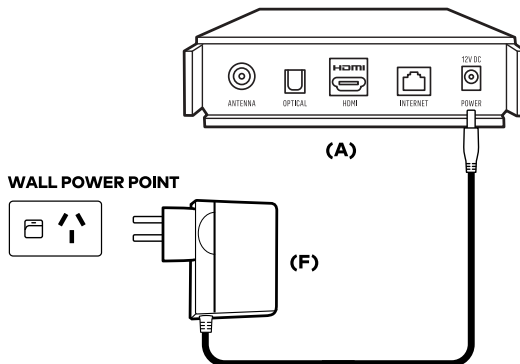

STEP 5

Time to switch it on!

- 1 Use your Fetch remote (H) to turn on your Fetch box (A).
- 2 Switch on your TV (K) with your TV remote (K).
- 3 Using your TV remote, press the 'AV SELECT', 'SOURCE' or 'INPUT' button (depending on your TV) and select the HDMI port you plugged your Fetch box into in Step 3 of the guide.

Handy Hint: if you connected via Ethernet cable or PLAs in Step 1 you'll know when you've found the correct input source when you see 'PREPARING SYSTEM PLEASE WAIT...' followed by the Fetch logo on screen.

If you're connecting via WiFi this will also appear once you're connected to the internet after following the 'GETTING WIFI CONNECTED' steps on the next page.

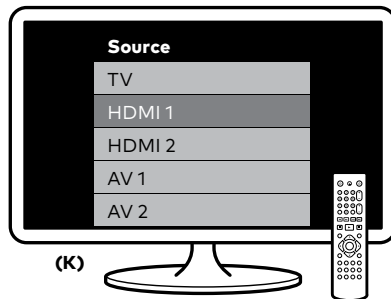

STEP 6

Follow the prompts and you're all set

GETTING WIFI CONNECTED

Your Fetch box will now check to see whether it's connected to the internet. It'll prompt you to connect to WiFi if you haven't already connected to the internet via Ethernet Cable or PLAs in Step 1. Here's what to do if you need to connect your WiFi:

- 1 Choose 'WiFi Connection' and follow the prompts.
- 2 Select your home network from the list of networks that are in range and confirm the security settings.
- 3 A prompt on screen will let you know once you're connected.

HEADS UP! There may be software updates when you set-up for the first time. As part of the updates, your TV screen may go blank a few times (for up to two minutes) and your Fetch box will also reboot – this is all normal so please don't turn it off during this time.

FINAL ON-SCREEN SET-UP

- 1 You'll now be taken through the final set-up stages on screen – it'll take about 5 to 15 minutes all up (depending on your broadband speed).
- 2 During this time you'll be prompted to enter your Activation Code (I) that we've previously sent you via email or SMS – so make sure to have it handy. If you have ordered multiple set top boxes for Multiroom, each set top box has its own unique activation code, however each code can be used on any Fetch box in the household. Your code (which is case-sensitive) will then be checked and confirmed. Can't find your code? No problem, just visit optus.com.au/activationcode
- 3 You'll also be prompted to set up a 'Parental PIN'. To create your own unique code just follow the prompts. You'll also need to use this code to purchase Movies and TV shows so it's a good one to remember. If you've already set the pin code on your account then you'll just need to confirm it.

HOW TO GET THE MOST FROM YOUR FETCH BOX

Add these extra options to get the most out of your new Fetch box.

SET-UP UNIVERSAL REMOTE

The universal remote lets you operate your TV and Fetch box all in one! Here's how:

- 1 Go to the 'MAIN MENU' and select 'MANAGE' then 'SETTINGS' and then 'REMOTE CONTROL'. From here all you need to do is follow the step-by-step instructions on screen.
- 2 You're all set!

DOWNLOAD THE FETCH APP

The Fetch app lets you watch selected content and control your Fetch box using your tablet or mobile phone at home or when you're out and about.

Here's how to get started:

- 1 Visit the App Store or Google Play and install the Fetch app on your phone or tablet.
- 2 Once the app has finished downloading its time to pair it with your Fetch box. To do this grab your Fetch remote (H), go to the 'MAIN MENU' then to 'MANAGE', 'SETTINGS' then 'MOBILE & TABLET' and follow the on-screen prompts.
- 3 Now you can enjoy being in control of your Fetch service from your mobile at home or when you're out and about.

Help and support

Got any issues, problems or head-scratchers?

We reckon you've been able to install your service without any hitches. But if you need a little extra help, have a read through our FAQs below or visit optus.com.au/fetch/userguide

If you still need a hand, feel free to give our Technical Support Team a call on **1300 760 013**. Please check that your internet connection is working and that everything is connected correctly before calling.

What if I have no picture on my TV?

Check that the TV is set to the correct input and mode (Step 5) and that all cables are connected securely. Alternatively, try connecting using different cables if you have spares handy at home.

What if I have no internet connection?

Check your modem is working by testing a website on your computer or other device that connects to your internet at home and also check the Ethernet Cable is securely connected.

If you're connecting using WiFi make sure your Fetch box is within range of your WiFi network.

If using a pair of Powerline Adaptors, check they're installed correctly. Refer to your Powerline Adaptors Quick Install Guide or access it from optus.com.au/fetch/plcinstall

My Remote Control isn't responding. What can I do?

Make sure you're using it within 6 metres of your Fetch box as it won't work beyond that. You can also try changing the batteries in the remote.

Why have the channels not scanned?

Double check that one end of your Antenna Cable is plugged into the 'ANTENNA' port on your Fetch box and the other end into the wall.

Then run another full channel scan by going to 'MENU' then to 'MANAGE', 'SETTINGS', 'CHANNELS' then to 'FULL CHANNEL SCAN'.

What happens if my Fetch box freezes?

Reboot it by turning the power off and on again (this may require turning the power off at the power point or unplugging the Power Cable from the box). You'll need to wait 30 seconds before turning the power back on.

DO NOT TURN THE POWER OFF WHILE YOUR FETCH BOX IS GOING THROUGH THE SET-UP PROCESS.

What if I don't have a spare Ethernet port on my modem?

You'll need to unplug an existing device from your modem to free up a port so you can plug-in the Ethernet Cable for your Fetch box.

And if I can't find my activation code?

No problem. Visit optus.com.au/activationcode





